



# Tête fraisée empreinte ÉTOILE

## BOIS & AGGLOMÉRÉS

### Acier inoxydable A2

## TX

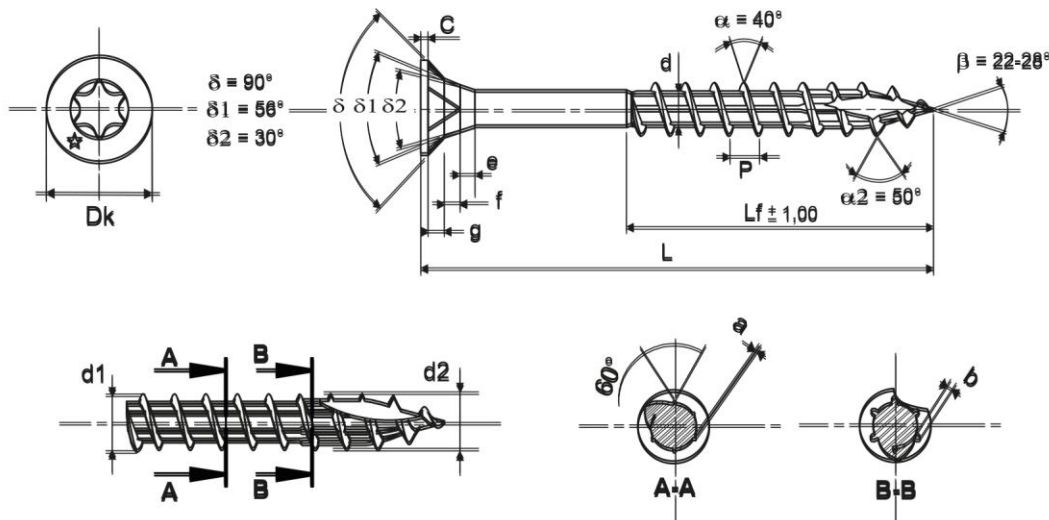

#### Caractéristiques

	Ø 3	Ø 3,5	Ø 4	Ø 4,5	Ø 5	Ø 6
Profondeur empreinte	1,30/1,60	1,40/1,70	1,40/1,70	1,80/2,10	2,10/2,40	2,40/2,70
N° empreinte	T10	T15	T20	T20	T25	T30
Dk	5,70 ± 0,20	6,70 ± 0,20	7,70 ± 0,20	8,70 ± 0,20	9,30 ± 0,20	11,30 ± 0,20
C	0,30/0,60	0,30/0,60	0,40/0,70	0,50/0,80	0,60/0,90	0,70/1,10
g	1,00	1,20	1,45	1,60	1,63	1,74
f	1,04	1,20	1,35	1,60	1,50	2,32
e	1,01	1,13	1,25	1,39	1,50	2,39
d	1,80/2,10	2,00/2,30	2,30/2,60	2,50/2,80	2,90/3,30	3,60/4,10
P	1,70 ± 10%	2,00 ± 10%	2,30 ± 10%	2,60 ± 10%	2,90 ± 10%	3,50 ± 10%
d1	2,95	3,45	3,95	4,45	4,95	5,95
d2	3,05	3,55	4,05	4,55	5,05	6,05
a/b	0,22/0,22	0,22/0,27	0,22/0,32	0,22/0,37	0,22/0,42	0,22/0,45

Pour les vis ROCKET de longueur inférieure à 25 mm, les diamètres d1 et d2 sont identiques.

Tous Ø L = 16	20/30	35/55	60/100*	110/120	130/160
Tolérance 0/- 0,90	0/- 1,05	0/- 1,25	0/- 1,50	0/- 1,75	0/- 2,00

\* 5x90/50 - 5x100/60 = 0/-1,75 6x80/50 = 0/-1,25



VYNEX - 22 Grande Rue - 08350 THELONNE  
Tél : 03 24 54 59 56 - Fax : 03 24 54 59 77