



DÉCLARATION DES PERFORMANCES



DoP: 0022

pour Connexion d'armatures avec résine d'injection fischer FIS HF (Résine pour scellement d'armatures rapportées) – FR

1. Code d'identification unique du produit type: **DoP: 0022**
2. Usage(s) prévu(s): **Scellement d'armatures rapportées (fers à béton, EN 1992-1-1) par ancrage ou recouvrement de joints dans un béton normal, voir annexe, en particulier annexes B 1 - B 10**
3. Fabricant: **fischerwerke GmbH & Co. KG, Otto-Hahn-Straße 15, 79211 Denzlingen, Allemagne**
4. Mandataire: --
5. Système(s) d'évaluation et de vérification de la constance des performances: **1**
6. Document d'évaluation européen: **EAD 330087-00-0601**

Évaluation technique européenne: **ETA-12/0555; 2018-06-27**

Organisme d'évaluation technique: **DIBt**

Organisme(s) notifié(s): **1343 – MPA Darmstadt**

7. Performance(s) déclarée(s):

Résistance mécanique et stabilité (BWR 1)

- **Résistance caractéristique sous charge statique et quasi-statique: Voir annexe, en particulier annexe C 1**

Protection contre le feu (BWR 2)

- **Réaction au feu: La cheville remplit les exigences de la classe A 1**
- **Résistance au feu: NPD**

8. Documentation technique appropriée et/ou documentation technique spécifique: ---

Les performances du produit identifié ci-dessus sont conformes aux performances déclarées. Conformément au règlement (UE) no 305/2011, la présente déclaration des performances est établie sous la seule responsabilité du fabricant mentionné ci-dessus.

Signé pour le fabricant et en son nom par:

Andreas Bucher, Dipl.-Ing.

Wolfgang Hengesbach, Dipl.-Ing., Dipl.-Wirtsch.-Ing.

Tumlingen, 2018-07-04

- Cette déclaration des performances a été émise en différentes langues. En cas de divergences d'interprétation, la version anglaise prévaut toujours.

- L'annexe contient des informations volontaires et complémentaires en langue anglaise dépassant les exigences légales (spécifiées en langage neutre).

Specific Part**1 Technical description of the product**

The subject of this European Technical Assessment is the post-installed connection, by anchoring or overlap connection joint, of reinforcing bars (rebars) in existing structures made of normal weight concrete, using the "Rebar connection with fischer injection mortar FIS HF" in accordance with the regulations for reinforced concrete construction.

Reinforcing bars made of steel with a diameter ϕ from 8 to 28 mm or the rebar anchor FRA from sizes 12, 16 and 20 according to Annex A and injection mortar FIS HF are used for rebar connections. The rebar is placed into a drilled hole filled with injection mortar and is anchored via the bond between rebar, injection mortar and concrete.

The product description is given in Annex A.

2 Specification of the intended use in accordance with the applicable European assessment Document

The performances given in Section 3 are only valid if the anchor is used in compliance with the specifications and conditions given in Annex B.

The verifications and assessment methods on which this European Technical Assessment is based lead to the assumption of a working life of the rebar connection of at least 50 years. The indications given on the working life cannot be interpreted as a guarantee given by the producer, but are to be regarded only as a means for choosing the right products in relation to the expected economically reasonable working life of the works.

3 Performance of the product and references to the methods used for its assessment**3.1 Mechanical resistance and stability (BWR 1)**

| Essential characteristic | Performance |
|---|---------------|
| Characteristic resistance under static and quasi-static loading | See Annex C 1 |

3.2 Safety in case of fire (BWR 2)

| Essential characteristic | Performance |
|--------------------------|-------------------------|
| Reaction to fire | Class A1 |
| Resistance to fire | No performance assessed |

4 Assessment and verification of constancy of performance (AVCP) system applied, with reference to its legal base

In accordance with European Assessment Document EAD No. 330087-00-0601, the applicable European legal act is: [96/582/EC].

The system(s) to be applied is (are): 1

Installation anchor

Figure A1:

Overlap joint with existing reinforcement for rebar connections of slabs and beams

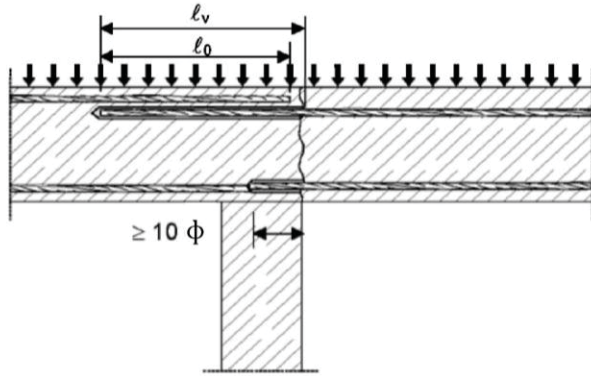

Figure A2:

Overlap joint with existing reinforcement at a foundation of a column or wall where the rebars are stressed

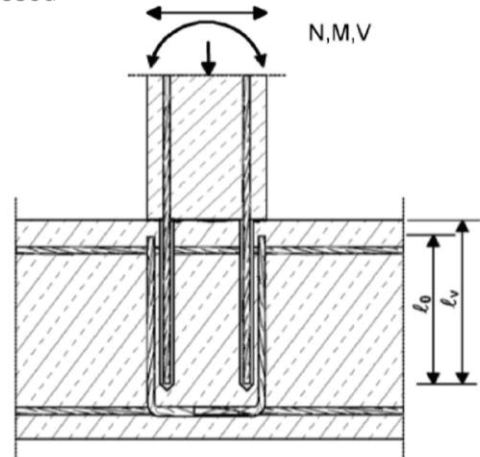

Figure A3:

End anchoring of slabs of beams (e.g. designed as simply supported)

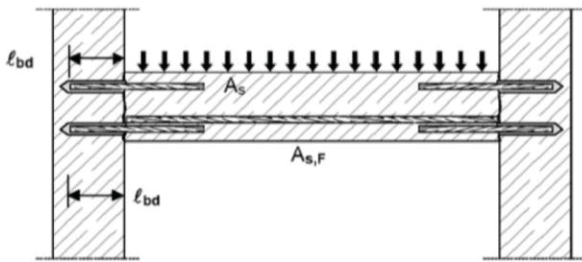

Figure A4:

Rebar connection for stressed primarily in compression

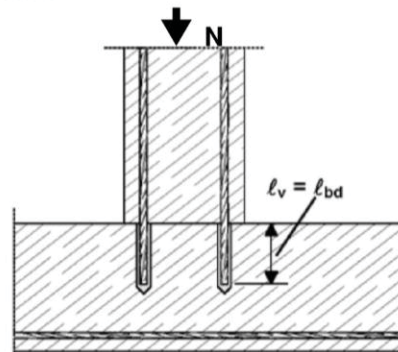
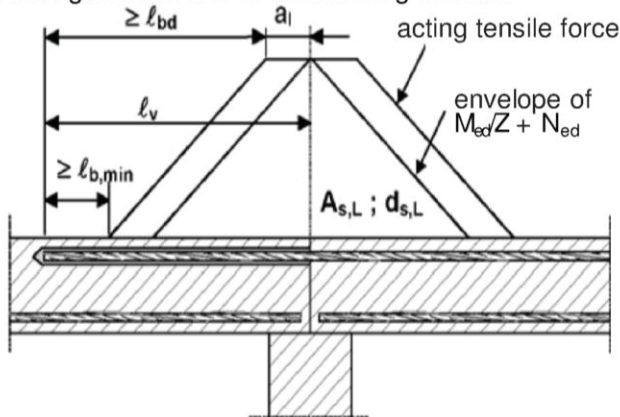

Figure A5:

Anchoring of reinforcement to cover the enveloped line of acting tensile force in the bending member



Note to **Figure A1 to A5**

In the Figures no traverse reinforcement is plotted, the traverse reinforcement shall comply with EN 1992-1-1: 2004+AC:2010.

Preparing of joints according to **Annex B 2**

Rebar connection with fischer injection mortar FIS HF

Product description

Installed condition and examples of use for rebars

Annex A 1

Installation anchor

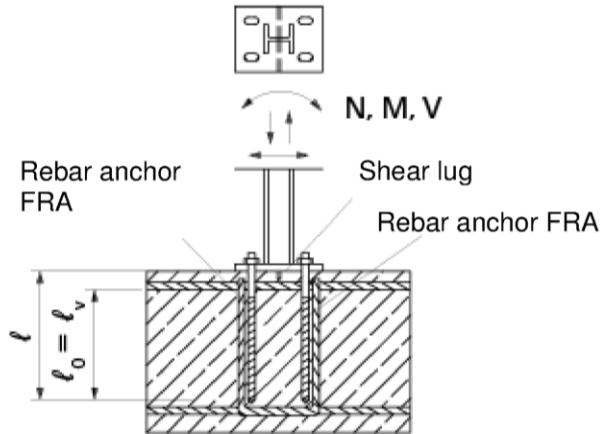

Figure A6: Lap to a foundation of a column under bending.

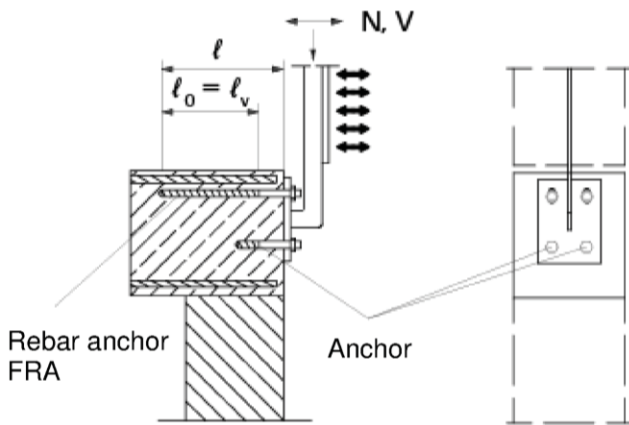

Figure A7: Lap of the anchoring of guardrail posts.
In the anchor plate, the drill holes for the rebar anchors FRA have to be designed as elongated holes with axial direction to the shear force.

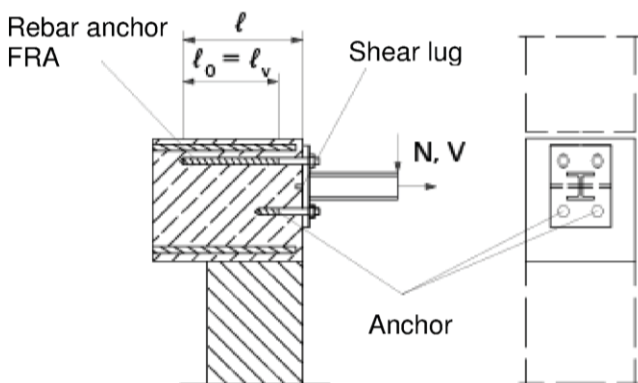

Figure A8: Lap of the anchoring of cantilevered building components.
In the anchor plate, the drill holes for the rebar anchors FRA have to be designed as elongated holes with axial direction to the

The required transverse reinforcement acc. to EN 1992-1-1:2004+AC:2010 is not shown in the figures. **The rebar anchor FRA may be only used for axial tensile force.** The tensile force must be transferred by lap to the existing reinforcement of the building. The transfer of the shear force has to be ensured by suitable measure, e.g. by means of shear force or anchors with European Technical Approval/Assessment (ETA)

Rebar connection with fischer injection mortar FIS HF

Product description

Installed condition and examples of use for rebar anchor FRA

Annex A 2

Injection cartridge fischer FIS HF

Shuttle cartridge, sizes: 345 ml, 360 ml, 390 ml, 550 ml, 1500 ml

Marking: FIS HF, processing notes, shelf-life, hazard code, curing times and processing times (depending on temperature), piston travel scale, size, volume

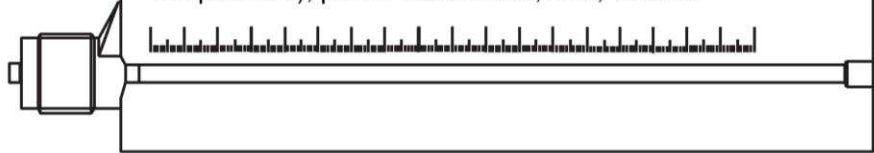
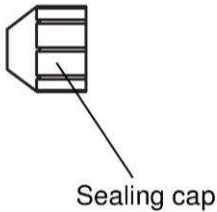

Coaxial cartridge, sizes: 300 ml, 380 ml, 400 ml, 410 ml

Marking: FIS HF, processing times, shelf-life, hazard code, curing times and processing times (depending on temperature), piston travel scale, size, volume

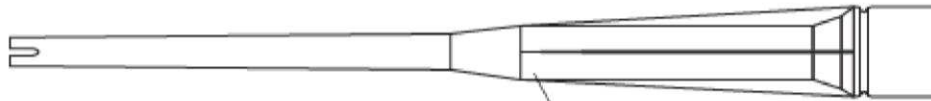
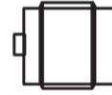
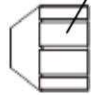

Static mixer FIS MR Plus or UMR

Rebar anchor FRA 12, 16, 20,

marking setting depth washer hexagon nut

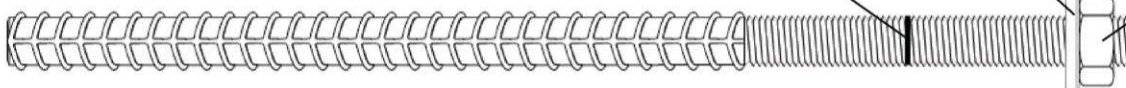

Reinforcing bar (rebar) ϕ 8, ϕ 10, ϕ 12, ϕ 14, ϕ 16, ϕ 20, ϕ 25, ϕ 28

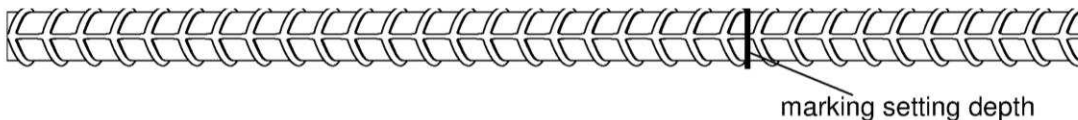

Rebar connection with fischer injection mortar FIS HF

Product description

Injection mortar; rebar anchor FRA; reinforcing bar

Annex A 3

Figure A9: Properties of reinforcing bars (rebar)



- The minimum value of related rip area $f_{R,min}$ according to EN 1992-1-1:2004+AC:2010
- The maximum outer rebar diameter over the ribs shall be:
 - The nominal diameter of the rip $\phi + 2 * h$ ($h \leq 0,07 * \phi$)
 - (ϕ : Nominal diameter of the bar; h : rip height of the bar)

Table A1: Materials of rebars

| Designation | Reinforcing bar (rebar) |
|--|---|
| Reinforcing bar EN 1992-1-1:2004+AC:2010, Annex C | Bars and de-coiled rods class B or C with f_{yk} and k according to NDP or NCL of EN 1992-1-1/NA $f_{uk} = f_{tk} = k \cdot f_{yk}$ |

Rebar connection with fischer injection mortar FIS HF

Product description
Properties and materials of rebars

Annex A 4

Figure A10: Properties of fischer rebar anchors FRA

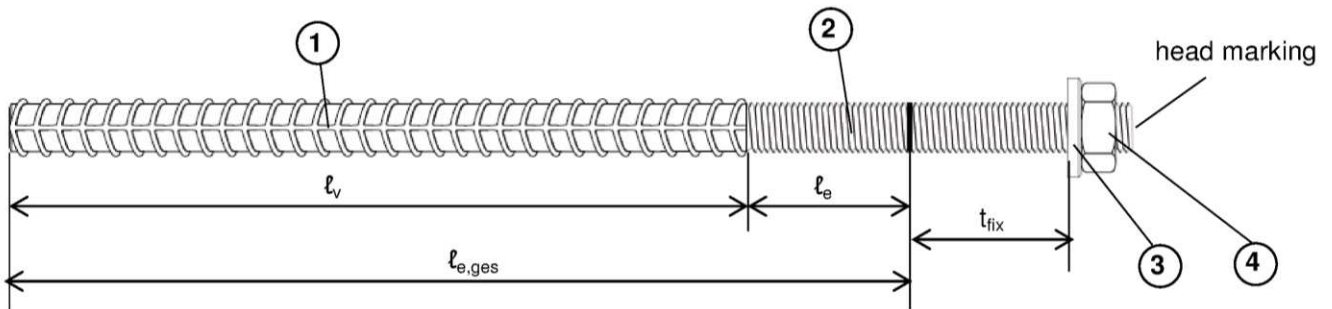

Head marking e.g.:  FRA (for stainless steel)

 FRA C (for high corrosion-resistant steel C)

Table A2: Installation parameters for fischer rebar anchors FRA

| Threaded diameter | | M12 | M16 | M20 | |
|---|--------------------------------|----------------------------|--------------|-----|----|
| Nominal diameter of the bar | ϕ [mm] | 12 | 16 | 20 | |
| Width across flat | SW [mm] | 19 | 24 | 30 | |
| Nominal drill bit diameter | d_0 [mm] | 14 ¹⁾ | 16 | 10 | 25 |
| Drill hole depth ($h_0 = l_{e,ges}$) | $l_{e,ges}$ [mm] | $l_v + l_e$ | | | |
| Effective embedment depth | l_v [mm] | acc. to static calculation | | | |
| Distance concrete surface to welded joint | l_e [mm] | 100 | | | |
| Diameter of clearance hole in the fixture | Pre-positioned $\leq d_f$ [mm] | 14 | 18 | 22 | |
| | Push through $\leq d_f$ [mm] | 18 | 22 | 26 | |
| Minimum thickness of concrete member | h_{min} [mm] | $h_0 + 30$ ≥ 100 | $h_0 + 2d_0$ | | |
| Maximum torque moment | $T_{inst,max}$ [Nm] | 50 | 100 | 150 | |

¹⁾ Both drill bit diameters can be used

Table A3: Materials of fischer rebar anchors FRA

| Part | Description | Materials | |
|------|---------------------------------------|--|--|
| | | FRA | FRA C |
| 1 | Reinforcing bar | Class B according to NDP or NCL acc. to EN 1992-1-1/NA; $f_{yk} = f_{tk} = k \cdot f_{yk}$ | |
| 2 | Round bar with partial or full thread | Stainless steel acc. to EN 10088-1:2014 | High corrosion-resistant steel acc. to EN 10088-1:2014 |
| 3 | Washer | Stainless steel acc. to EN 10088-1:2014 | High corrosion-resistant steel acc. to EN 10088-1:2014 |
| 4 | Hexagon nut | Stainless steel acc. to EN 10088-1:2014 Strength class 80; acc. to EN ISO 3506:2009 | High corrosion-resistant steel acc. to EN 10088-1:2014 Strength class 80; acc. to EN ISO 3506:2009 |

Rebar connection with fischer injection mortar FIS HF

Product description

Properties and materials of fischer rebar anchors FRA

Annex A 5

Specifications of intended use

Anchorage subject to:

- Static and quasi-static loads

Base materials:

- Reinforced or unreinforced normal weight concrete according to EN 206-1:2000
- Strength classes C12/15 to C50/60 according to EN 206-1:2000
- Maximum chloride concrete of 0,40% (CL 0.40) related to the cement content according to EN 206-1:2000
- Non-carbonated concrete

Note: In case of a carbonated surface of the existing concrete structure the carbonated layer shall be removed in the area of the post-installed rebar connection with a diameter of $\phi + 60$ mm prior to the installation of the new rebar

The depth of concrete to be removed shall correspond to at least the minimum concrete cover in accordance with EN 1992-1-1:2004+AC:2010

The foregoing may be neglected if building components are new and not carbonated and if building components are in dry conditions

Temperature Range:

- -40°C to +80°C (max. short term temperature +80°C and max long term temperature +50°C)

Use conditions (Environmental conditions) for fischer rebar anchors FRA:

- Structures subject to dry internal conditions (fischer rebar anchors FRA and FRA C)
- Structures subject to external atmospheric exposure (including industrial and marine environment) and to permanently damp internal condition, if no particular aggressive conditions fischer rebar anchors FRA and FRA C)
- Structures subject to external atmospheric exposure and to permanently damp internal condition, if other particular aggressive conditions exist (fischer rebar anchors FRA C)

Note: Particular aggressive conditions are e.g. permanent, alternating immersion in seawater or the splash zone of seawater, chloride atmosphere of indoor swimming pools or atmosphere with extreme chemical pollution (e.g. in desulphurization plants or road tunnels where de-icing materials are used)

Design:

- Anchorages are designed under the responsibility of an engineer experienced in anchorages and concrete work
- Verifiable calculation notes and drawings are prepared taking account of the forces to be transmitted
- Design according to EN 1992-1-1:2004+AC:2010 and Annex B 2 and Annex B3
- The actual position of the reinforcement in the existing structure shall be determined on the basis of the construction documentation and taken into account when designing

Installation:

- Dry or wet concrete
- It must not be installed in flooded holes
- Overhead installation allowed
- Hole drilling by hammerdrill or compressed airdrill mode
- The installation of post-installed rebar respectively fischer rebar anchor FRA shall be done only by suitable trained installer and under Supervision on site; the conditions under which an installer may be considered as suitable trained and the conditions for Supervision on site are up to the Member States in which the installation is done
- Check the position of the existing rebars (if the position of existing rebars is not known, it shall be determined using a rebar detector suitable for this purpose as well as on the basis of the construction documentation and then marked on the building component for the overlap joint)

Rebar connection with fischer injection mortar FIS HF

Intended use
Specifications

Annex B 1

Figure B1: General construction rules for post-installed rebars

- Only tension forces in the axis of the rebar may be transmitted
- The transfer of shear forces between new concrete and existing structure shall be designed additionally according to EN 1992-1-1:2004+AC:2010
- The joints for concreting must be roughened to at least such an extent that aggregate protrude

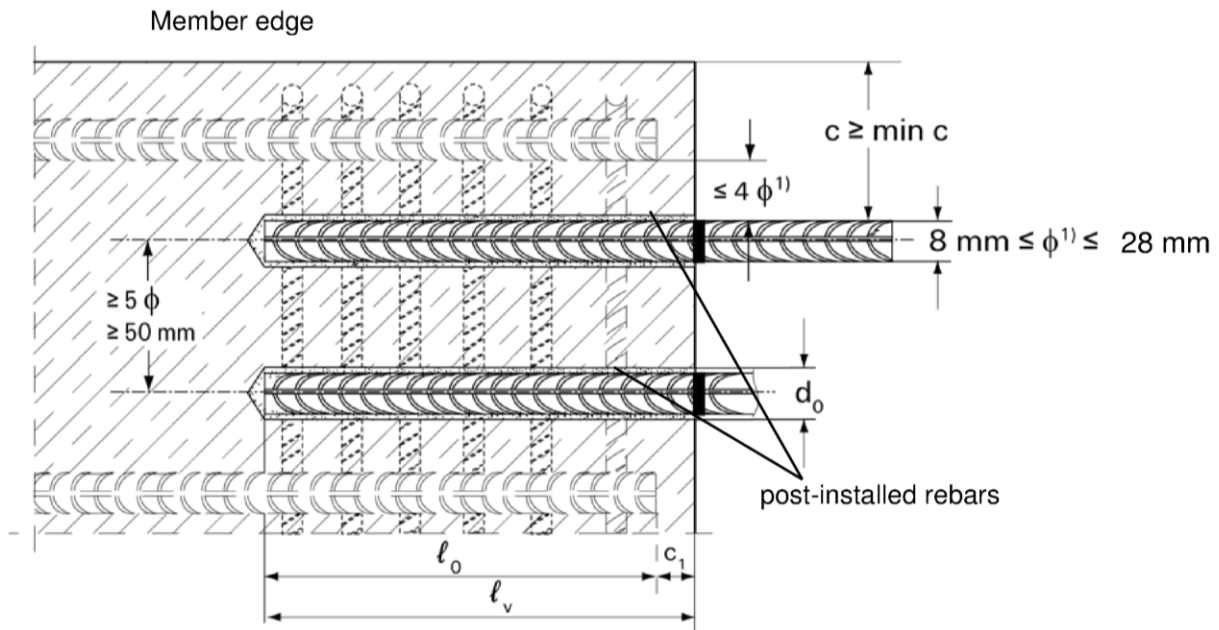

¹) If the clear distance between lapped bars exceeds 4ϕ then the lap length shall be increased by the difference between the clear bar distance and 4ϕ

- c concrete cover of post-installed rebar
- c_1 concrete cover at end-face of existing rebar
- min c minimum concrete cover according to Table B1 and to EN 1992-1-1:2004+AC:2010, Section 4.4.1.2
- ϕ nominal diameter of the bar
- ℓ_0 lap length, according to EN 1992-1-1:2004+AC:2010, Section 8.7.3
- ℓ_v effective embedment depth, $\geq \ell_0 + c_1$
- d_0 nominal drill bit diameter, see Annex B 5

Rebar connection with fischer injection mortar FIS HF

Intended use

General construction rules for post-installed rebars

Annex B 2

Figure B2: General construction rules for post-installed rebar anchors FRA

- Only tension forces in the axis of the FRA may be transmitted
- The tension force must be transferred via an overlap joint to the reinforcement in the building part.
- The transmission of the shear load shall be ensured by appropriate additional measures, e.g. by shear lugs or by anchors with an European Technical Assessment (ETA).
- In the anchor plate, the holes for the tension anchor shall be executed as elongated holes with the axis in the direction of the shear force.

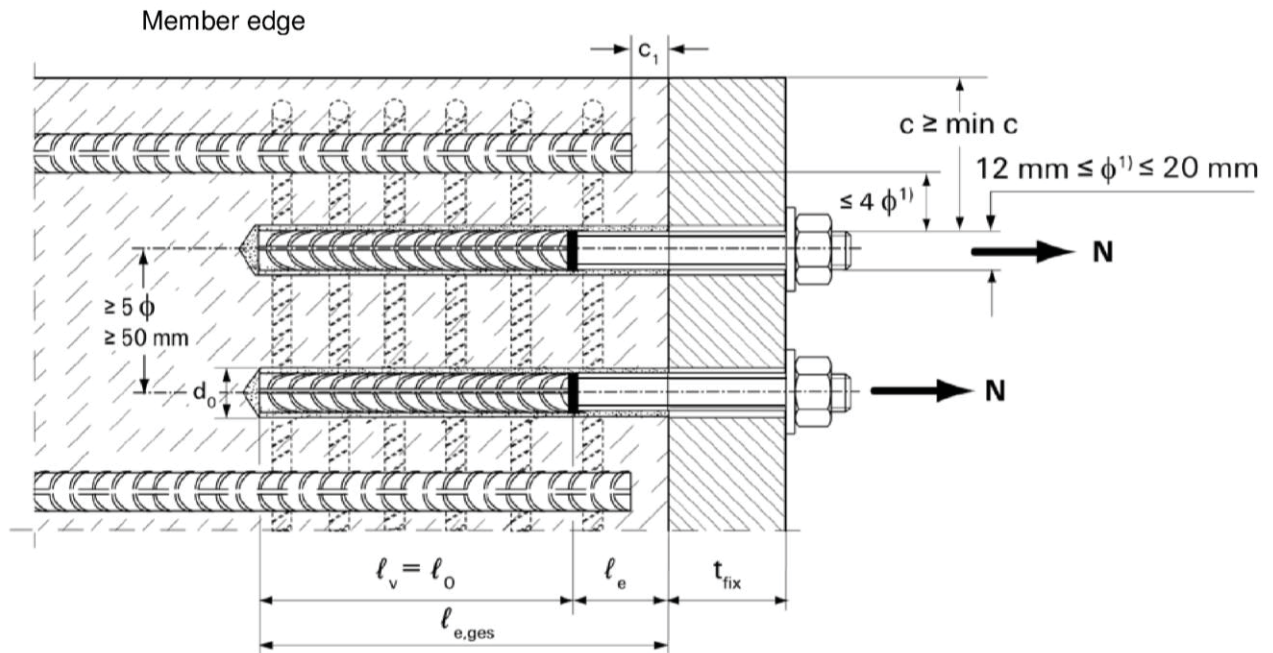

¹⁾ If the clear distance between lapped bars exceeds 4ϕ then the lap length shall be increased by the difference between the clear bar distance and 4ϕ

- c concrete cover of post-installed FRA
- c_1 concrete cover at end-face of existing rebar
- min c minimum concrete cover according to Table B1 and to EN 1992-1-1:2004+AC:2010, Section 4.4.1.2
- ϕ nominal diameter of the bar
- l_0 lap length, according to EN 1992-1-1:2004+AC:2010, Section 8.7.3
- $l_{e,ges}$ overall embedment depth, $\geq l_v + l_e$
- l_e length of the bonded in threaded part
- d_0 nominal drill bit diameter, see Annex B 5
- t_{fix} thickness of the fixture
- l_v effective embedment depth

Rebar connection with fischer injection mortar FIS HF

Intended use

General construction rules for post-installed rebar anchors FRA

Annex B 3

Table B1:
Minimum concrete cover $c^{1)}$ depending of the drilling method and the drilling tolerance

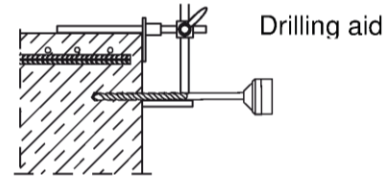

| Drilling method | Nominal diameter of the bar ϕ [mm] | Minimum concrete cover min c | |
|-------------------------|---|------------------------------|-----------------------------------|
| | | Without drilling aid [mm] | With drilling aid [mm] |
| Hammer drilling | ≤ 20 | 30 mm + 0,06 ℓ_v | 30 mm + 0,02 $\ell_v \geq 2 \phi$ |
| | ≥ 25 | 40 mm + 0,06 ℓ_v | 40 mm + 0,02 $\ell_v \geq 2 \phi$ |
| Compressed air drilling | ≤ 20 | 50 mm + 0,08 ℓ_v | 50 mm + 0,02 ℓ_v |
| | ≥ 25 | 60 mm + 0,08 ℓ_v | 60 mm + 0,02 ℓ_v |

¹⁾ See Annex B2, Figure B1 and Annex B3, Figure B2

Note: The minimum concrete cover as specified in EN 1992-1-1:2004+AC:2010 must be observed

Table B2:
Dispensers and cartridge sizes correspondending to maximum embedment depth $\ell_{v,max}$

| Rebar / FRA | Manuel dispenser | Accu and pneumatic dispenser (sml) | pneumatic dispenser (great) |
|-------------|--|--|-----------------------------|
| | Cartridge size | | |
| | < 500 ml; | >500 ml | |
| ϕ [mm] | $\ell_{v,max} / \ell_{e,ges,max}$ [mm] | $\ell_{v,max} / \ell_{e,ges,max}$ [mm] | |
| 8 | 1000 | 1000 | 1800 |
| 10 | | 1200 | |
| 12 / FRA 12 | | 1500 | |
| 14 | | 1300 | |
| 16 / FRA 16 | 700 | 1000 | 2000 |
| 20 / FRA 20 | | 700 | |
| 25 | 500 | 700 | |
| 28 | | | |

Table B3: Working times t_{work} and curing times t_{cure}

| Temperature in the anchorage base [°C] | Maximum working times ¹⁾ t_{work} [minutes] | Minimum curing times ²⁾ t_{cure} [minutes] |
|--|---|--|
| | FIS HF | FIS HF |
| > \pm 0 to +5 | 13 ³⁾ | 180 |
| >+5 to +10 | 9 ³⁾ | 90 |
| >+10 to +20 | 5 | 60 |
| >+20 to +30 | 4 | 45 |
| >+30 to +40 | 2 ⁴⁾ | 35 |

¹⁾ Maximum time from the beginning of the injection to rebar / FRA setting and positioning

²⁾ For wet concrete the curing time must be doubled

³⁾ If the temperature in the concrete falls below 0°C the cartridge has to be warmed up to +15°C.

⁴⁾ If temperatures exceed 30 °C, cool the cartridge to +15°C...+20°C

Rebar connection with fischer injection mortar FIS HF

Intended use

Minimum concrete cover/ Maximum embedment depth per dispenser and cartridge size/ Working times and curing times

Annex B 4

Table B4:
Installation tools for drilling and cleaning the bore hole and injection of the mortar

| Rebar / FRA ϕ [mm] | Drilling and cleaning | | | | | | Injection | | | |
|----------------------------|--|------------------|--|-------------|------------------------------------|------|-------------------------|------------------------|-------------------------------|--------|
| | Nominal drill bit diameter d_0 [mm] | | Diameter of cutting edge d_{cut} [mm] | | Steel brush diameter d_b [mm] | | Cleaning nozzle [mm] | Extension tube [mm] | Injection adapter [colour] | |
| 8 | 10 ¹⁾ | 12 ¹⁾ | $\leq 10,5$ | $\leq 12,5$ | 11,0 | 12,5 | 11 | 9 | - | nature |
| 10 | 12 ¹⁾ | 14 ¹⁾ | $\leq 12,5$ | $\leq 14,5$ | 12,5 | 15 | | | nature | blue |
| 12 / FRA 12 | 14 ¹⁾ | 16 ¹⁾ | $\leq 14,5$ | $\leq 16,5$ | 15 | 17 | | | blue | red |
| 14 | 18 | | $\leq 18,5$ | | 19 | | 15 | 9 or 15 | yellow | |
| 16 / FRA 16 | 20 | | $\leq 20,55$ | | 25 | | | | green | |
| 20 / FRA 20 | 25 | | $\leq 25,55$ | | 26,5 | | | | black | |
| 25 | 30 | | $\leq 30,55$ | | 32 | | grey | | | |
| 28 | 35 | | $\leq 35,70$ | | 37 | | brown | | | |
| | | | | | | | 28 | | | |

¹⁾ Both drill bit diameters can be used

Rebar connection with fischer injection mortar FIS HF

Intended use

Installation tools for drilling and cleaning the bore hole and injection installation of the mortar

Annex B 5

Safety regulations



Review the Material Safety Data Sheet (SDS) before use for proper and safe handling!

Wear well-fitting protective goggles and protective gloves when working with mortar fischer FIS HF

Important: Observe the instructions for use provided with each cartridge.

1. Drill hole

Note: Before drilling, remove carbonized concrete; clean contact areas (see Annex B 1)

In case of aborted drill hole the drill hole shall be filled with mortar.

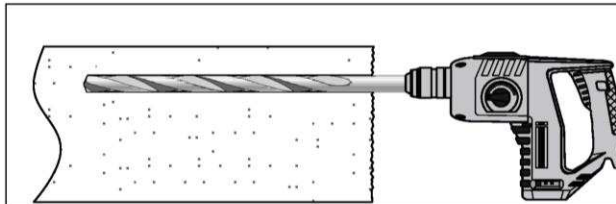

Drill hole to the required embedment depth using a hammer-drill with carbide drill bit set in rotation hammer mode or a compressed air drill.

Drill bit sizes see Table B4.

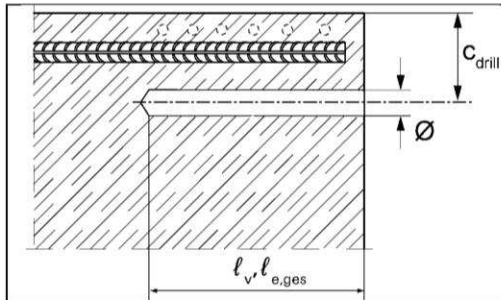

Measure and control concrete cover c

$$c_{drill} = c + \phi / 2$$

Drill parallel to surface edge and to existing rebar

Where applicable use fischer drilling aid.

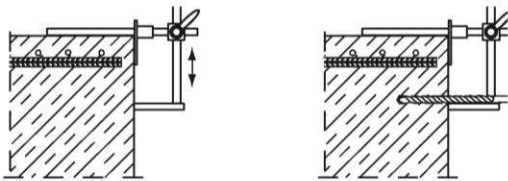

For holes $l_v > 20$ cm use drilling aid.

Three different options can be considered:

- A) fischer drilling aid
- B) Slat or spirit level
- C) Visual check

Rebar connection with fischer injection mortar FIS HF

Intended use

Installation instruction part 1

Annex B 6

2.1 Compressed air cleaning

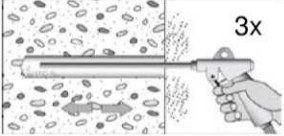
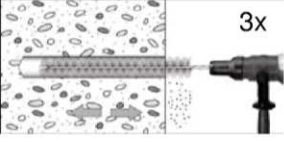
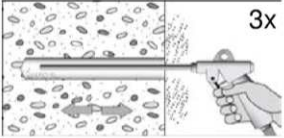

| | |
|---|---|
|  | <p>Blowing three times from the back of the hole with oil-free compressed air (min. 6 bar) until return air stream is free of noticeable dust.</p> |
|  | <p>Brushing (with power drill) three times with the specified brush size (brush diameter >: borehole diameter) by inserting the round steel brush to the back of the hole in a twisting motion. The brush shall produce natural resistance as it enters the anchor hole. If this is not the case, please use a new brush or a brush with a larger diameter. For appropriate brushes see Table B4.</p> |
|  | <p>Blowing three times from the back of the hole with oil-free compressed air (min. 6 bar) until return air stream is free of noticeable dust.</p> |

Rebar connection with fischer injection mortar FIS HF

Intended use
Installation instruction part 2

Annex B 7

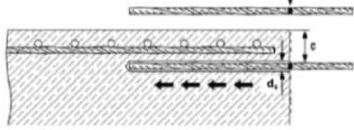
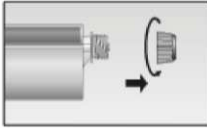
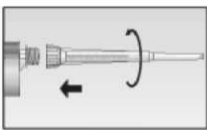
3. Preparation of the rebar or rebar anchor FRA and the cartridge

| | |
|--|--|
|  | <p>Before use, make asure that the rebar or the rebar anchor FRA is dry and free of oil or other residue. Mark the embedment depth on the rebar (e.g. with tape) l_v Insert rebar in borehole, to verify hole and setting depth l_v resp. $l_{e,ges}$</p> |
| Injection system preparation | |
|  | <p>No. 1: Twist off the sealing cap</p> |
|  | <p>No. 2: Twist on the static mixer (the spiral in the static mixer must be clearly visible).</p> |
|  | <p>No. 3: Place the cartridge into a suitable dispenser.</p> |
|  | <p>No. 4: Press out approximately 10 cm of mortar until the resin is permanently grey in colour. mortar which is not grey in colour will not cure and must be disposed of.</p> |

4. Inject mortar into borehole

4.1 borehole depth ≤ 250 mm:

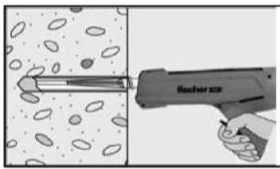
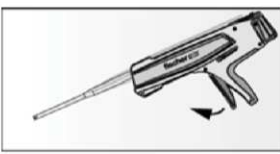



| | |
|---|---|
|  | <p>Inject the mortar from the back of the hole towards the front and slowly withdraw the mixing nozzle step by step after each trigger pull. Fill approximately 2/3 full, or as required to ensure that the annular gap between the rebar and the concrete is completely filled with adhesive over the embedment length.</p> |
|  | <p>After injecting, depressurize the dispenser by pressing the release trigger. This will prevent further mortar discharge from the mixing nozzle.</p> |

Rebar connection with fischer injection mortar FIS HF

Intended use
 Installation instruction part 3

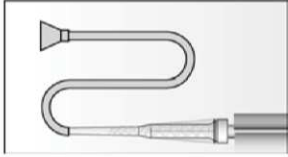
Annex B 8

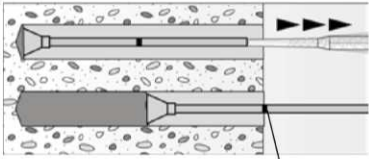
4.2 borehole depth > 250 mm:



| | |
|---|---|
|  | <p>Assemble mixing nozzle, extension tube and injection adapter (see Table B 4)</p> |
|  <p>Mortar level mark</p> | <p>Mark the required mortar level l_m and embedment depth l_v resp. $l_{e,ges}$ with tape or marker on the injection extension tube.</p> <p>a) Estimation:</p> $l_m = \frac{1}{3} * l_v \text{ resp. } l_m = \frac{1}{3} * l_{e,ges}$ <p>b) Precise formula for optimum mortar volume:</p> $l_m = l_v \text{ resp. } l_{e,ges} \left((1,2 * \frac{d_s^2}{d_0^2} - 0,2) \right) [\text{mm}]$ |
|  <p>Mortar level mark</p> | <p>Insert injection adapter to back of the hole. Begin injection allowing the pressure of the injected adhesive mortar to push the injection adapter towards the front of the hole.</p> <p>Fill holes approximately 2/3 full, or as required to ensure that the annular gap between the rebar and the concrete is completely filled with adhesive over the embedment length.</p> <p>When using an injection adapter continue injection until the mortar level mark l_m becomes visible.</p> <p>Maximum embedment depth see Table B 2</p> |
|  | <p>After injecting, depressurize the dispenser by pressing the release trigger. This will prevent further mortar discharge from the mixing nozzle.</p> |

Rebar connection with fischer injection mortar FIS HF

Intended use
Installation instruction part 4

Annex B 9

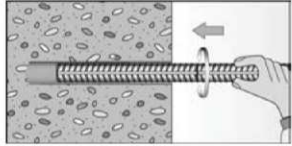
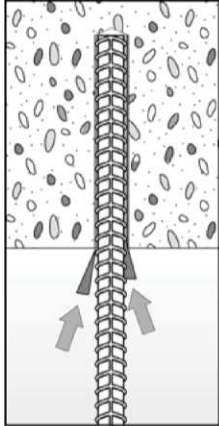
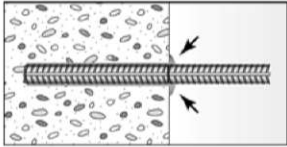
4.3 Insert rebar or rebar anchor FRA

| | |
|---|--|
|  | <p>For each installation insert the rebar / rebar anchor FRA slowly twisted into the borehole until the embedment mark is at the concrete surface level.</p> |
|  | <p>For overhead installation support rebar / rebar anchor FRA and secure it from falling till mortar started to harden, e.g. using wedges.</p> |
|  | <p>After installing the rebar / rebar anchor FRA the annular gap must be completely filled with mortar.</p> <p>Proper installation</p> <ul style="list-style-type: none"> • Desired anchoring embedment is reached l_v: embedment mark at concrete surface. • Excess mortar flows out of the borehole after the rebar has been fully inserted until the embedment mark. |
|  | <p>Observe the working time "t_{work}" (see Table B3), which varies according to temperature of base material. Minor adjustments to the rebar / rebar anchor FRA position may be performed during the working time</p> <p>Full load may be applied only after the curing time "t_{cure}" has elapsed (see Table B 3)</p> |

Rebar connection with fischer injection mortar FIS HF

Intended use
Installation instruction part 5

Annex B 10

Minimum anchorage length and minimum lap length

The minimum anchorage length $\ell_{b,min}$ and the minimum lap length $\ell_{o,min}$ according to EN 1992-1-1:2004+AC:2010 ($\ell_{b,min}$ acc. to Eq. 8.6 and Eq. 8.7 and $\ell_{o,min}$ acc. to Eq. 8.11) shall be multiply by an amplification factor α_{lb} according to Table C1.

Table C1: Amplification factor α_{lb} related to concrete class and drilling method

| Concrete class | Drilling method | Amplification factor α_{lb} |
|------------------|---|------------------------------------|
| C12/15 to C50/60 | Hammer drilling and compressed air drilling | 1,0 |

Table C2: Reduction factor k_b for all drilling methods

| Rebar / FRA | Reduction factor k_b | | | | | | | | |
|----------------|------------------------|--------|--------|--------|--------|--------|--------|--------|--------|
| | Concrete class | | | | | | | | |
| ϕ [mm] | C12/15 | C16/20 | C20/25 | C25/30 | C30/37 | C35/45 | C40/50 | C45/55 | C50/60 |
| 8 bis 28 | 1,0 | | | | | | | | |
| FRA M10 to M20 | | | | | | | | | |

Table C3: Design values of the ultimate bond resistance $f_{bd,PIR}$ in N/mm² for all drilling methods and for good bond conditions

$$f_{bd,PIR} = k_b \cdot f_{bd}$$

f_{bd} : Design value of the ultimate bond stress in N/mm² considering the concrete classes and the rebar diameter according to EN 1992-1-1: 2004+AC:2010

(for all other bond conditions multiply the values by 0,7)

k_b : Reduction factor according to Table C2

| Rebar / FRA | Bond resistance $f_{bd,PIR}$ [N/mm ²] | | | | | | | | |
|----------------|---|--------|--------|--------|--------|--------|--------|--------|--------|
| | Concrete class | | | | | | | | |
| ϕ [mm] | C12/15 | C16/20 | C20/25 | C25/30 | C30/37 | C35/45 | C40/50 | C45/55 | C50/60 |
| 8 bis 28 | 1,6 | 2,0 | 2,3 | 2,7 | 3,0 | 3,4 | 3,7 | 4,0 | 4,3 |
| FRA M10 to M20 | | | | | | | | | |

Rebar connection with fischer injection mortar FIS HF

Performances

Amplification factor α_{lb} , Reduction factor k_b

Design values of ultimate bond resistance $f_{bd,PIR}$

Annex C 1